

Introduction to Networking (NSW1141)

Libor Forst, SISAL MFF UK

- Essential facts concerning communications
- Layered network model (OSI vs. TCP/IP, addressing, multiplexing, ...)
- Application layer (DNS, FTP, email, web, VoIP, ...)
- Transport layer
- Network layer (IPv4, IPv6, routing, firewalls, ...)
- Data link and physical layer (switch vs. repeater, Ethernet, Wi-Fi, cabling, ...)

Literature

- D. E. Comer, D. L. Stevens: Internetworking With TCP/IP; Prentice Hall 1991
- A. S. Tanenbaum: Computer Networks; Prentice Hall 2003
- C. Hunt: TCP/IP Network Administration; O'Reilly & Associates 1992
- internet resources
- Request For Comment (RFC)
- <http://www.warriorsofthe.net>

General attributes of communication

- Identification
 - actors must „find“ themselves (phone numbers) and introduce each other
- Method
 - e.g.: a deaf man at a counter tries sign language, the officer doesn't understand and suggests written form of communication
- Language
 - both sides must agree on a common language
- Speed
 - both sides must agree on a communication speed
- Process
 - requests, answers, confirmations

Types of communication

- Ordinary human communications
 - voice, signals, writing
 - loose intuitive rules
- Telecommunication
 - complex technology with embedded rules
 - entire network (incl. end devices) is under centralized control
- Computer network
 - rules are open and freely accessible
 - most of logic is moved to end devices
 - network controls just the transmission
- Converged network
 - joins telecomm. and computer worlds (price, effectiveness...)
 - better is convergence based on computer network

Message transmission (mail)

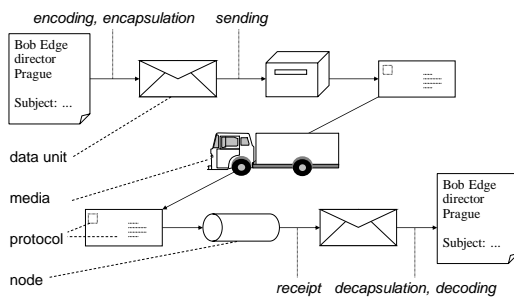

Message transmission (e-mail)

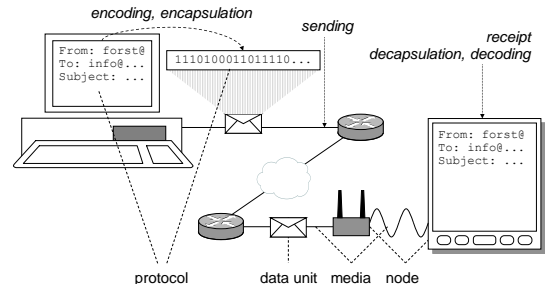

Computer network history

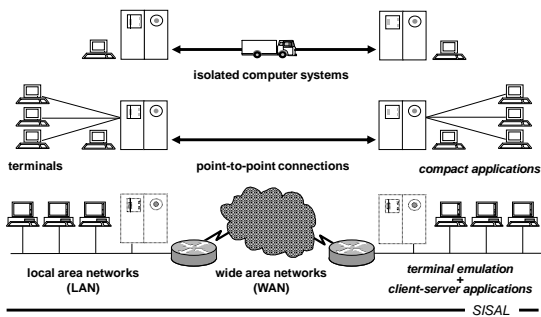

Basic network types

- Local Area Network (LAN)
 - resources sharing (file- and database-servers, printers,...)
 - shorter distances (building, campus), minor delay
 - proprietary networks, centralized control
- Wide Area Network (WAN)
 - remote access, end-to-end communication
 - large distances, notable delay
 - multiple owners, distributed control
- Nowadays:
 - differences fade away (most important is possession)
 - interlayers occur (MAN)
- Classification is not technical (no definition), but logical

Public and private networks

- Most LAN are private (user is the owner)
- Most non-LAN are public (user is not owner)

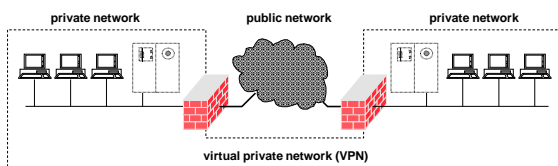

- VPN motivation: security, expenses
- Typical use of VPN: affiliates interconnections, connection of (mobile) end users

Requirements - fault tolerance

- circuit switching: faster, fluent, however failures disrupt whole connection
- packet switching: packets use various ways => transport time may differ, but network can overcome node failures

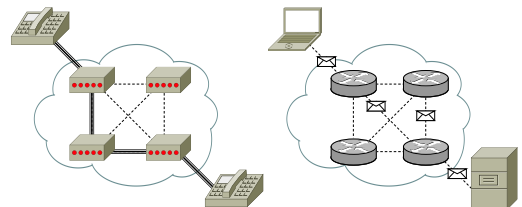

Requirements – security I

- Original motivation:
 - physical security of transmission
- In the early days of networks, there was little risk of network attack other than physical destruction
- Old technologies were naive:
 - open communication (tapping possible)
 - full confidence in partner identity
 - content trust

Requirements – security II

- Security risks:
 - infrastructure (physical) security
 - data (logical) security
 - DoS (Denial of Service)
- Infrastructure security:
 - access restrictions
 - backup power sources, air conditioning...
 - backup servers, connectivity...
- Data security:
 - user authentication, access rights control
 - host authentication (servers, clients)
 - data inspection (application proxy, antivirus, antispam, ...)
 - cryptography (ciphers, encryption, subscription)

Requirements - scalability (LAN)

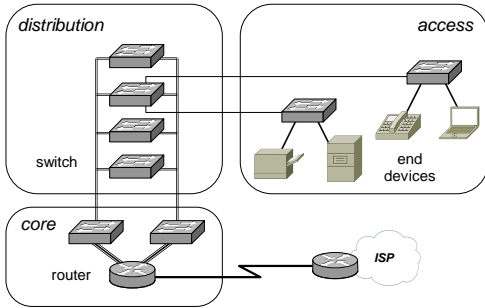

Requirements - scalability (WAN)

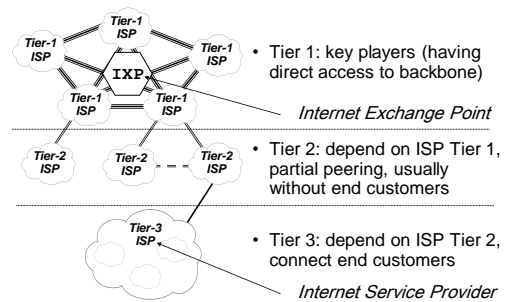

Requirements - quality of service (I)

- Network transmission parameters:
 - latency, delay
 - evenness of delivery (*jitter*, variance of delay)
 - data loss
 - bandwidth („speed“)
- Various applications have various requirements:
 - multimedia applications: low jitter
 - data transfer: low data loss
 - ...

Requirements - quality of service (II)

- Goal:
 - guarantee dedicated throughput for particular traffic types
 - guarantee faster delivery of priority messages
- Implementation:
 - data is classified by QoS tag
 - *guaranteed service* strategy: dedicated part of channel
 - quality guaranteed, wasting of channel capacity
 - *best effort* strategy: priority queues
 - effective media usage, quality not guaranteed

Internet history

- beg. of the 60s - „packet switching“ concept
- the 60s - US DoD supports „packet switching“ concept for its resistance against a physical attack
- 1969 - ARPANET - paid by Defense Advanced Research Project Agency, managed by academic institutions, point-to-point leased lines
- 1974 - term „Internet“ (abbr. of „internetworking“) used in RFC 675 defining TCP
- 1977 - first network bound to ARPANET backbone
- 1983 - TCP/IP replacing NCP in ARPANET
- half of the 80s - TCP/IP included into BSD UNIX

Internet progress

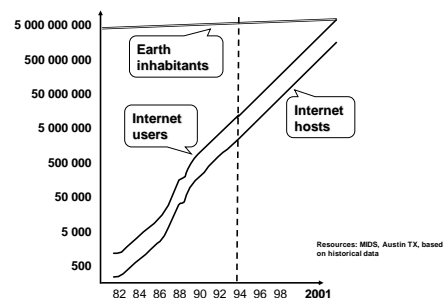

Request for Comments (RFC)

- Means of Internet „standardization“
- RFC 1 published Apr 7, 1969

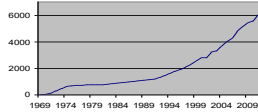

- Freely accessible (<http://www.ietf.org/rfc.html>)
- Various nature: standards, information, best-practice
- Drafts are sent to and judged by IAB ⇒ IETF, IRTF ⇒ WG
- Document texts are fixed, upgrades obtain new number (SMTP: 772, 780, 788, 821, 2821, 5321)
- Current status can be found in the index file
- Recommendations are widely violated

Summary 1

- What are the advantages and disadvantages of packet switching?
- How have network protocols been affected by the fact that the idea of networking was initiated by the army to increase the security of communication?
- What is the purpose of the network scalability requirement?
- How do the demands of e-mail and IP telephony differ regarding the transmission parameters of the network?
- What is the definition of a LAN?
- What is the essence of a VPN?

Layered architecture

- Example: sending of minutes from a meeting
 - layer Recorder
 - writes minutes
 - rules: minutes outline
 - request to Secretary: send a message [minutes; person list]
 - layer Secretary
 - adds a header, footer, inserts into envelopes, write addresses
 - rules: commercial message form
 - request to Registry: send [message; addresses]
 - layer Registry
 - stamps envelopes, places into a packet, send to a post office
 - rules: mail rules
- Benefits:
 - simpler decomposition and description of the entire process
 - easy technology change (mail/e-mail, post/messenger)
 - inter-layer co-operation (only Registry goes to the post)

Network model, network architecture

- Network (reference) model:
 - number of layers and their structure
 - distribution of tasks among layers
 - e.g.: OSI model (ISO)
- Network (protocol) architecture (suite):
 - network model
 - communication technologies
 - services and protocols
 - e.g.: TCP/IP

Open Systems Interconnection

- OSI: Basic Reference Model + set of protocols
- Model: used for documentation and teaching
- Protocols: built from the top, megalomaniac, inconvenient

Layer	Function
7 Application	End application communication
6 Presentation	Data conversions for applications
5 Session	End nodes dialog control
4 Transport	End-to-end data blocks transmission
3 Network	Routing across networks
2 Data link	Transmission of data frames between two nodes
1 Physical	Transmission of bit streams over a medium

X.400, X.500

- OSI services implementation was based on a set of complex standards, e.g.
 - X.400: Message Handling System (e-mail), some time played the core role in Microsoft Exchange Server; address example:
G=Labor; S=Forst;
O=Charles University;
OU=Faculty of Mathematics and Physics;
OU=SISAL;
C=cz
 - X.500: Directory Access Protocol (directory services like phone book), note: *default attribute of a person is a favorite drink*
- Descendants:
 - X.509 Public Key Infrastructure – public key management
 - LDAP (Lightweight DAP) – database of information about users and service

TCP/IP stack

- Grown according to needs, developed gradually

OSI	Layer	Protocol examples		
7	application	FTP, HTTP, SMTP	DNS, SIP	NFS
6				XDR
5				RPC
4	transport	TCP	UDP	
3	network	IP		ICMP
2	network interface	Ethernet, FDDI, ATM, WiFi, SLIP, PPP, ...		ARP
1				

Connection-oriented/connectionless services

- Connection-oriented services
 - real-life example: phone call
 - *reliable* packet delivery guaranteed
 - simpler application logic, lack of communication control
 - in TCP/IP, TCP is used
- Connectionless services
 - real-life example: mail
 - neither order nor delivery of packets guaranteed (*unreliable*)
 - control logic must be included in the application
 - in TCP/IP, UDP is used (IP itself is also unreliable)

Application models

- Client-server model
 - client knows the fixed server address
 - client connects to the server, or sends requests
 - server usually handles more clients
 - data flow server \Rightarrow client: download
 - data flow client \Rightarrow server: upload
 - examples: DNS, WWW, SMTP
- Peer-to-peer (P2P) model
 - partners do not know data resource addresses
 - no clear roles
 - each partner plays the role of both the client and server
(=offer data!)
 - Napster, Gnutella, BitTorrent

Hosts addressing

- **HW** (data link layer)
 - **MAC address** (physical)
(e.g. Ethernet: 8:0:20:ae:6:1f)
 - factory given (formerly), programmed (now)
 - does not respect topology
- **SW** (network layer)
 - **IP address**
(e.g.: 194.50.16.71, ::1)
 - assigned according to network topology
 - given border between net and host part
- **People** (application layer)
 - **domain address**
(e.g.: www.mff.cuni.cz)
 - assigned according to the organization structure
 - easy to remember or deduce

Domain Name System

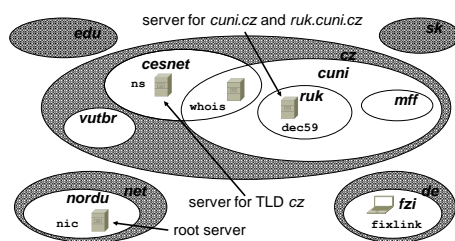

Domain administration

- Top-level domains (administered by ICANN):
 - technical (**arpa**)
 - groups by categories (**com, org, edu, mil, gov, net**) later extended (**info, biz, aero, ...**)
 - ISO country codes (**cz, sk, ...**) and some exceptions (**uk, eu**); countries with interesting names (**nu, tv**) sell names
 - internationalized codes (.中国 = .xn--fiqs8s, .pф)
 - currently even private TLDs are allowed
- TLD **.cz**:
 - administered by CZ.NIC (ISP corporation)
 - no structure, circa 1.4 mil. names under **.cz**
 - no support for localized names (IDN)
- SLDs and lower level domains:
 - administered by owner (**ms.[mff].[cuni.cz]**)

IP addresses

- Every end node in TCP/IP network must have an IP address
- Current versions:
 - IPv4: 4 bytes (e.g. 195.113.19.71)
 - IPv6: 16 bytes (e.g. 2001:718:1e03:a01::1)
- Address block assignment:
 - public addresses for network is assigned by its ISP
 - LAN can use private addresses, unreachable from the internet (security vs. interoperability), *address translation* (NAT)
- Host address assignment:
 - method (fixed vs. dynamic, free vs. limited) is defined by LAN administration
 - even for private addresses, exception: *link-local* addresses

Port, socket

- **Port**
 - ... 16bit integer identifying one end of the communication channel - an application, or a process responsible for incoming data processing
 - *destination-port* must be known by clients, usually it is one of so-called *well-known services* (formerly < 1024)
 - *source-port* is assigned by the originator's OS from unused port numbers (*generic port*)
- **Socket**
 - ... one end of the communication channel between the client and the server
 - ... identification ("address") of the channel end <IP address, port>

Well-known services examples

- **21/TCP: FTP** - File Transfer Protocol (file transfer)
- **22/TCP: SSH** - Secure Shell (remote logging and file transfer)
- **25/TCP: SMTP** - Simple Mail Transfer Protocol (electronic mail transfer)
- **53/*: DNS** - Domain Name System (conversion between IP addresses and names)
- **80,443/TCP: HTTP** - HyperText Transfer Protocol (transfer of web pages)
- **5060,5061/*: SIP** - Session Initiation Protocol (VoIP, IP telephony)

Network address translation (NAT)

- General principle: a local network with *private* addresses using for outside traffic *public* ones (or other private ones)
- Other term: *IP masquerading*
- Implementation and terminology can slightly differ in details

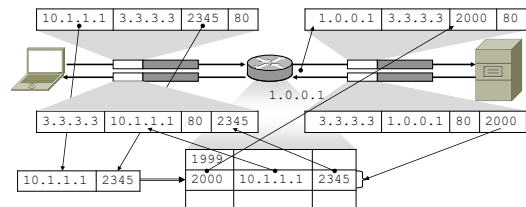

Services addressing

- Uniform Resource Identifier (URI, RFC 3986)
 - unified resource reference system (HTML links)
 - one client can use various access methods (FTP in WWW)
 - former classification: URL (location), URN (name)

URI = scheme: [//] authority [path] [?query] [#fragment]
authority = [login[:password]@]address[:port]

e.g.: **ftp://sunsite.mff.cuni.cz/Net/RFC**
http://1.2.3.4:8080/q?ID=123#Local
mailto:forst@cuni.cz
sip:221911111@voip.cz

Data flow in TCP/IP

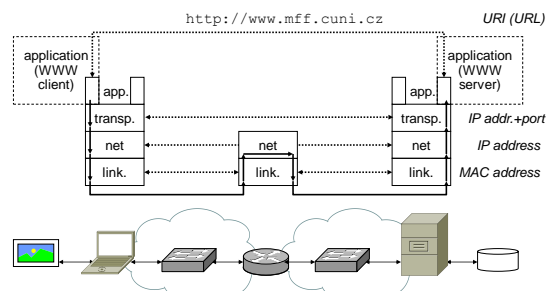

Multiplexing, encapsulation

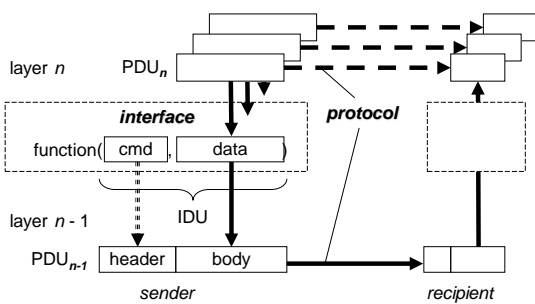

PDU types in TCP/IP

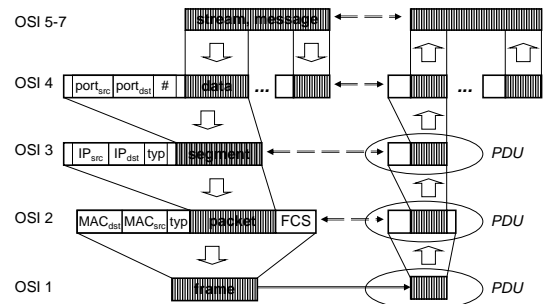

Summary 2

- Describe the differences between TCP, UDP and IP.
- Which addresses are used at the application, transport, network, data link and physical layer?
- What is the difference between the client-server and peer-to-peer application mode?
- How are domain names administered?
- How are IP addresses assigned?
- What is the meaning and principle of NAT?
- What is multiplexing and encapsulation?

Authentication, authorization

- **Authentication** is a process for subject identity verification. **Authorization** is a process for defining set of services for an already identified subject.
- Methods for local identification:
 - knowledge test (password, PIN, ...)
 - possession of technical items (key, HW token, ...)
 - biometrics (fingerprints, ...)
- Remote identification:
 - eavesdropping protection: one-time password, cryptography
 - protocol incorporation: e.g. via SASL (a general model used in protocols according to specific profiles, e.g. in SMTP)
 - using of authentication server and authentication protocol (LDAP, RADIUS, NTLM, Kerberos, SAML)

One Time Password (OTP)

- General term for mechanisms allowing non-repeatable plain-text user authentication
- Old off-line method:
 - Printed list of single-shot passwords.
- Older on-line method "challenge-response":
 - Server sends single-shot randomized key, user uses defined procedure how to create the answer (e.g. by a special HW or SW calculator combining the received key and the user password) and sends it back.
- Newer method:
 - User gets a special authentication item (token), which is exactly synchronized with the server and generates a time-limited single-shot authentication code.

Symmetric cryptography

- Historical: additive, transposition, substitution ciphers, cipher grids and tables
- Nowadays: the same principles converted to digital form and supported by mathematical theory
- Key: the same key for encryption and decryption
- Examples: DES, Blowfish, AES, RC4
- Pros: fast, suitable for large data
- Cons: partners must safely exchange a common key

Asymmetric cryptography

- Keys: a pair of (mutually nondeductible) keys for encryption and decryption
- Mathematical principle: one-way functions
 - multiplication vs. factoring
 - discrete logarithm $m = p^k \bmod q$
- Examples: RSA, DSA, ECDSA
- Pros: no need of shared secret, one key (public) is free for distribution, the other (private) one must be secured
- Cons: slow, suitable only for small data
- Crucial problem: the public key must be **carefully verified**

Cryptographic hash functions

- Hash functions:
 - calculation of a fixed size piece of code from the given text
 - many applications (fast comparison, table election, ...)
 - examples: CRC, MD5
- Using in cryptography:
 - extra security requirements
 - minor text change = major change of hash, „almost unique“
 - one-way function, finding a text from a hash is “hard”
 - finding another text with the same hash is “hard”
 - examples: SHA

Data encryption

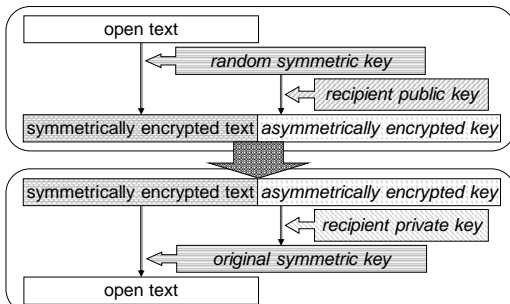

Digital signature

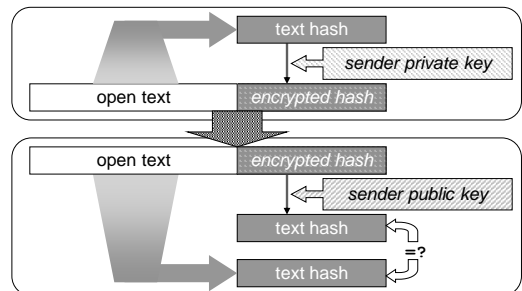

Diffie-Hellman algorithm

- Method of information exchange between two partners via an open channel to get a common secret (e.g. a symmetric key)
- Used in many protocols exploring the symmetric cryptography
- Procedure description:
 1. Alice picks a secret number a and public primes p and q .
 2. She computes $A = p^a \bmod q$ and sends p , q , and A to Bob.
 3. Bob picks a secret number b , computes $B = p^b \bmod q$ and sends B to Alice.
 4. Alice computes $s = B^a \bmod q$ and Bob the same $s = A^b \bmod q$.
- Principle:
 - $A^b = (p^a)^b = p^{ab} = p^{ba} = (p^b)^a = B^a$
 - Without knowing of secret numbers a and b and when choosing large prime numbers p and q , computing the s from A and B is considered to be “hard”.

Public key authenticity

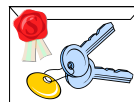

- Does the identity tag belong to the key?
 - people usually can make sure that they communicate with the proper partner prior to disclosing some secret
 - the key may be and should be verified from independent sources
 - applications must use some automated way
- Authenticity is verified by a third party and its signature is appended; this can be
 - someone who is known by me and I have his or her key verified (“web of trust”)
 - well-known public certification authority; listed e.g. in browsers, however such list’s credibility is not absolutely sure

Certificate

- Certificate is a key with an owner identification tag, signed by an issuer, e.g. certification authority (CA)
- Trusting the issuer, we can trust the key owner (**verifying the CA credibility needed!**)
- Certificate structure by X.509 (RFC 3280; SSL, not SSH):
 - certificate
 - certificate version
 - certificate serial number
 - issuer
 - validity dates
 - public key owner
 - public key information (algorithm and key)
 - certificate signature algorithm
 - certificate signature

SSL, TLS

- Secure Socket Layer 3.0 ~ Transport Layer Security 1.0, **obsoleted nowadays**, current version: 1.3 (RFC 8446)
- Interlayer between the transport and application layer allowing authentication and encryption
- Many protocols uses it (e.g. HTTPS on port 443)
- Principle:
 1. A client sends a request for an SSL connection + parameters.
 2. The server responses with parameters and own certificate.
 3. The client verifies the server, generates a common key basis, encrypts it by the server public key and sends it back.
 4. The server decrypts the key basis. Using this basis, both the client and the server generate common encryption key.
 5. The client and the server mutually negotiate, that from this moment both will encrypt their communication by this key.

Application layer in TCP/IP

- Covers functions of OSI layers 5, 6 and 7
 - communication rules between client and server
 - dialog status
 - data interpretation
- Application layer protocol defines
 - dialog control flow on both sides
 - message format (textual/binary data, structure,...)
 - message types (requests and responses)
 - message and information fields semantics
 - transport layer interaction

Domain Name System

- Client-server application for names to addresses resolution
- Binary protocol over UDP & TCP, port 53, RFC 1034, 1035
 - Common requests (up to 512B if not EDNS) use UDP
 - Larger data transfers use TCP
- Client contacts servers defined in its configuration, getting information about other servers until he finds the answer
- Data unit is called resource record (RR), e.g.:

```
ns.cuni.cz. 3600 IN A 195.113.19.78
```

 - RR name
 - validity time (TTL)
 - type and data

DNS resource records

Type	RR name semantics	Data semantics
SOA	domain name	general domain attributes
NS	domain name	domain nameserver name
A,AAAA	host name	host IPv4/6 address
PTR	reverse name (e.g. IP address 1.2.3.4 is represented by 4.3.2.1.in-addr.arpa, ::1 by 1.0..0.ip6.arpa)	host domain name
CNAME	alias name	canonical (real) host name
MX	domain/host name	mailserver name and priority
SVCB	service name	priority, target, parameters

DNS servers

- Server types:
 - **primary**: manages the domain RR database
 - **secondary**: downloads and keeps a copy of the RR database
 - **caching-only**: keeps just (un)resolved requests within their validity time
- Every domain (zone) must have at least one (better more) **authoritative** (primary or secondary) nameservers
- Data exchanges run over TCP with regular query/answer form (data is sent as DNS RRs)
- Zone database actualization is started by the secondary server, but the primary one can signal the need of updates

Response codes

- For simpler automated processing of responses, they start with 3-digit number
- The first digit expresses response severity:
 - 1xx **positive preliminary reply** (action was started, further responses expected)
 - 2xx **positive completion reply**
 - 3xx **positive intermediate reply** (further commands necessary)
 - 4xx **transient negative completion reply** (action failed, however repeating later makes sense)
 - 5xx **permanent negative completion reply** (action failed and will fail later, too)
- A similar schema adopted by many protocols

Active/passive data connection

- Every data transfer uses new (data) connection
- Active data connection establishment:

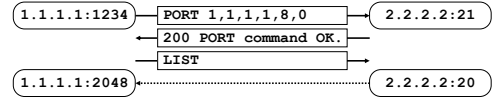

- Passive data connection establishment:

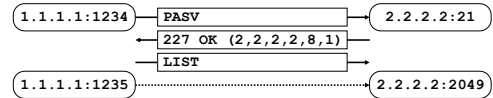

- After data transfer closing, the connection is terminated

Applications for FTP

- WWW browsers
- file managers (Total Commander)
- command-line **ftp** client
 - session opening: **open, user**
 - session closing: **close, quit, bye**
 - remote commands: **cd, pwd, ls, dir**
 - file management: **delete, rename, mkdir, rmdir**
 - local commands: **lcd, !command** (!cd generally does not work!)
 - file transfer: **get, put, mget, mput**
 - file transfer mode: **ascii, binary** (mind text/binary file transfers between different OS!)
 - miscellaneous: **prompt, hash, status, help,...**

Distributed database principle

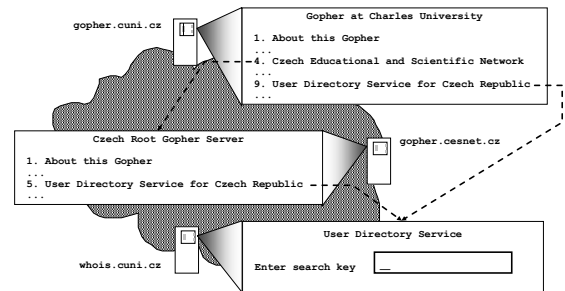

Hypertext

- **The first idea (1945):**
non-linear hierarchical text containing references that allow to continue reading of more detailed information, or similar topic
- **The later extension (1965):**
adding some non-textual information (images, sound, video...); sometimes called *hypermedial text*
- **Practical implementation (1989):**
World Wide Web system developed in CERN

World Wide Web

- WWW is a distributed hypertext database
- The basic information unit is called hypertext *page* (document) sent by a server to clients on demand
- Documents are written in textual form using HTML (Hypertext Markup Language)
 - describes both content and form
 - final view depends on the client SW and configuration
- Pages are either static (URL path typically corresponds with the real path in the server filesystem) or dynamic (on-line generated according to the client request)
- Page transfer is driven by the Hypertext Transfer Protocol (HTTP), lack of security is solved by the TLS interlayer (HTTP+SSL=HTTPS)

HTTP example

URL: `http://www.cuni.cz/index.html`

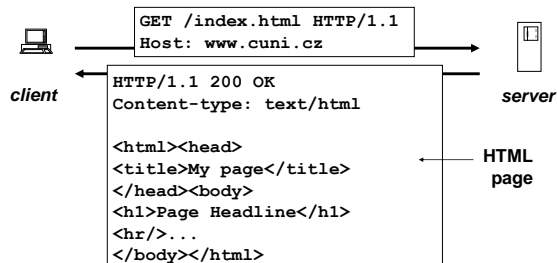

Hypertext Transfer Protocol v.1

- Currently still mostly version 1.1, RFC 9112, port 80
- General message form:
 - the first line (request/response)
 - additional header lines
 - request: language, charset, page age, authentication,...
 - response: document type, encoding, expiration,...
 - (optional) document body
- Status (response) codes:
 - 1xx **informational** (provisional response, processing continues)
 - 2xx **success** (final response)
 - 3xx **redirection** (some additional client request expected)
 - 4xx **client error** (incorrect request)
 - 5xx **server error** (transient or permanent error on server)

HTTP methods

Method	Request body	Response body	Safe, Idempotent	
GET	—	document	yes	yes
HEAD	—	—	yes	yes
POST	parameters	document	no	no
PUT	document	—	no	yes
DELETE	—	result	no	yes
CONNECT	↔ tunnel ↔			

HTTP v.1 properties

- One request typically leads to a single document (page, picture,...)
- One (persistent) connection can serve for more requests, clients usually open more connections at the same time in parallel
- Individual requests are independent, the communication is stateless; state must be carried via additional data, so called *cookies*:
 - the server generates cookies based on a data from the user and sends them to the client in HTTP headers
 - the browser stores them and sends them in HTTP request header when contacting the same server
 - servers can use data from cookies to collect information about users

Hypertext Transfer Protocol v.2

- Main motivation: better throughput
- Current version described in RFC 9113
 - binary protocol, switching from v.1 connection is possible
- Methods:
 - multiplexing "*streams*" within a single TCP connection (streams do not block each other, can be prioritized)
 - server can *push* more data than requested if it guesses that client will request it immediately
 - headers have grown extensively, often repeated in many requests - thus, compression is effective and is used
- Rejected feature: obligatory encryption

Hypertext Transfer Protocol v.3

- The trend started by HTTPv2 shifted in further development
- New protocol leaves TCP and uses a new transport protocol QUIC (RFC 9000, originally an acronym of Quick UDP Internet Connections):
 - UDP extension with embedded TLS 1.3
 - an extremely compressed handshake
 - own stream management
 - connection identifications independent on source – support of migrating clients
 - each packet encrypted individually
- HTTPv3 (RFC 9114) is based on the principles of HTTPv2 and adapts them for use via QUIC

Hypertext Markup Language

- Progress in past decade has been a little bit dramatic, in 2014 released a compromise version 5
- Textual page content is supplemented by meta-tags: structural (e.g. paragraph), semantic (e.g. post address), formatting (e.g. bold)
- Application of older SGML (Standard Generalized ML) and predecessor to XML (Extensible ML)
- Tag form: `<tag [attributes]>`
- Whitespaces not significant
- Special chars - entities (`<`, `>`, `&`, ` `;...)
- Comments (`<!-- ... -->`)

HTML - document structure

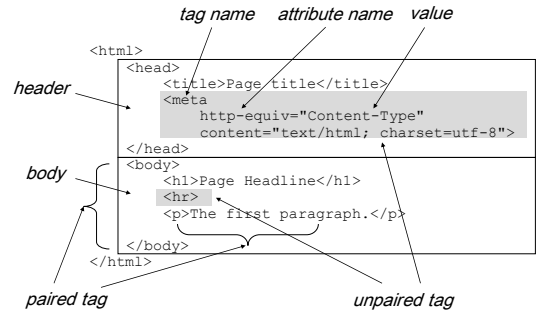

HTML - hypertext

- References - tag *anchor*:
 - another page reference: `...`
 - fragment positioning: ``
 - fragment reference: `...`
- Images - tag *image* (`img`), attributes:
 - `src` image source URI
 - `alt` alternative text for text-only clients
 - `width, height` display size of the picture
 - `border` border line

HTML - formatting

- Basic formatting:
 - paragraph (`<p>...</p>`)
 - headline (`<h1>` to `<h6>`)
 - line break (`
`)
 - horizontal line (`<hr>`)
 - centering (`<center>`)
- Font specification:
 - explicit: ``
 - physical: bold (``), italic (`<i>`), underscore (`<u>`), fixed size (`<tt>`), index (`<sub>`)...
 - logical: emphasis (``, ``), source code example (`<code>`)...

HTML - lists

```

<ul>
<li>item A</li>
<li>item B</li>
</ul>

<ol>
<li>item A</li>
<li>item B</li>
</ol>

<dl>
<dt>term A</dt>
<dd>explanation</dd>
<dt>term B</dt>
<dd>explanation</dd>
</dl>
    
```

The diagram shows three types of HTML lists. On the left, the source code for each is provided. On the right, a visual representation shows:

- An unordered list with two items: "item A" and "item B".
- An ordered list with two items: "1. item A" and "2. item B".
- A definition list with two terms: "term A" with "explanation" and "term B" with "explanation".

HTML - tables

```

<table border="1">
<tr>
<td colspan="2">Period</td>
<td>Income</td>
</tr><tr>
<td rowspan="2">2012</td>
<td>I - III</td>
<td align="right">10</td>
</tr><tr>
<td>IV - VI</td>
<td>2000</td>
</tr>
</table>
    
```

The diagram shows the source code for an HTML table and its visual output. The table has a border of 1. The first row has two columns: "Period" and "Income". The second row has three columns: "2012", "I - III", and "10". The third row has three columns: "IV - VI", "2000", and an empty cell. The visual output shows the table with the specified attributes.

HTML - forms

```
<form action="mailto.cgi" method="post">
Name: <input name="name">
Text: <textarea name="text"
      rows="3" cols="40"></textarea>
Send
<input type="radio"
      name="when" value="n">
now
<input type="radio"
      name="when" value="l">
later
<input type="submit"
      value="Process">
</form>
```

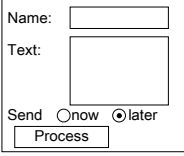

Cascading Style Sheets

- Formatting directly in HTML is complicated
- CSS introduce way how to
 - define properties for whole areas of page
 - create own formatting styles
 - inherit and modify properties of other styles
- CSS ease maintenance of large page sets conforming given formatting rules
- Example:

```
<style type="text/css">
h1 {color: blue; font-style: italic;}
</style>
```

Page view responsibility

1. Page author
 - introduces basic idea to the page
 - depth of the idea depends on him/her
2. Type and version of browser
 - different (versions of) browsers can interpret identical source code different ways
 - checking the view on various browsers is recommended
3. Browser configuration
 - user usually can affect some attributes of page view by the configuration (e.g. to choose strategy of fonts and colors using)

Dynamic pages (server-side)

Dynamics driven by the server, no code runs on the client.

- Sending an HTML form leads to running so called *cgi-script* on the server which generates dynamic page text using parameters entered by the user into the form and transferred in the URI, or in the request body
- Page author can request the server SW to include some pieces of text to the page (so called *server-side includes*)
- Page can contain a code for *the HTML preprocessor* (PHP), the client get just the result (date and time here)

```
<?php
echo date(DATE_RFC822);
?>
```

PHP has wide range of libraries, e.g. for database handling

Dynamic pages (client-side)

Moving the dynamics (running the code) to the client.

- Java - a language based on C++ ideas, with emphasis on security issues, with libraries for simple creation of the user interface
- Java programs (*applets*) are transferred to clients in form of platform independent **bytecode**, clients interpret and execute it using local libraries
- Javascript - a similar principle, however, the **source code** is being transferred to clients and interpreted there, e.g.:

```
<script>
document.write("<b>WARNING</b>");
</script>
```

Today libraries can even communicate with the server.

Telnet

- Remote host access protocol, port 23
 - Abbreviation from *Telecommunication Network*
 - One of the oldest protocols, first definition RFC 97 (1971!)
 - The user has a network virtual terminal (NVT), the protocol carries chars and NVT control commands in both directions (weakness: e.g. no difference between request/response)
 - Main problem: clear-text data transfer (solved in extension in RFC 2946, too late)
 - Today:
 - network devices access within separate LAN segment
 - other protocol debugging:
- ```
> telnet alfik 25
220 alfik.ms.mff.cuni.cz ESMTP Sendmail ...
HELO betynka
250 alfik Hello betynka, pleased to meet you
```

## Secure Shell (SSH)

- Secured replacement of older protocols for remote access and file transfer
  - client tries to verify server
  - communication is encrypted
- Current version 2, RFC 4250-4254, port 22
- SSHv2 extends the possibilities by:
  - opening more secured channels at the same time
  - tunneling different protocols through secured channels
  - accessing the filesystem (SSHFS)
- Clients (Windows): putty, winscp
- Commands (Unix):
 

```
ssh [user@]host [command]
scp [-pr] [user@[host:]]file1 [user@[host:]]file2
```

## Security in SSH

- Clients verify servers
  - according to a public key (confirmed by a user)
  - according to its certificate (signed by trusted CA)
- Servers authenticate users
  - using the password
  - using a challenge/response system (OTP)
  - using public keys (the server sends a challenge encrypted by the user key, the client sends the plain-text response)
- Key usage strategy
  - carefully verify the server key, beware namely when **key change** is announced („*man-in-the-middle*“ attack danger)
  - permit passwordless login just for private key with password
  - less-important accounts could have passwordless login, but never mutually (A→B & B→A) - protection against *worms*

## Summary 4

- What are the most important FTP security risks?
- What is the nature of the problems in opening additional data channels?
- What is the purpose of HTML?
- Describe what happens in the HTTP/1.1 protocol if a user requests a page with two embedded images.
- Briefly describe the purpose and properties of the most common HTTP methods.
- What are cookies for and what are their risks?
- Compare the Telnet and SSH protocols.

## Electronic mail

- General service, exists also out of the Internet
  - off-line sending of messages or files
  - off-line usage of information services
  - mailing-lists, conferences
  - communication outside the Internet
- In TCP/IP based on RFC 821, 2821 and 5321 (SMTP, or ESMTP) and RFC 822, 2822 and 5322 (message format) on the port 25
- General form of e-mail address in the Internet:
 

*login@host* or *alias@domain*

e.g.:

**forst@ms.ms.mff.cuni.cz** or **Libor.Forst@cuni.cz**

## E-mail delivery in SMTP

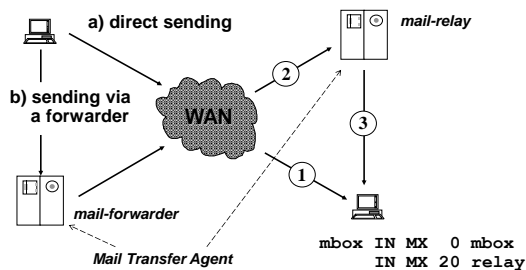

## User approach to e-mail

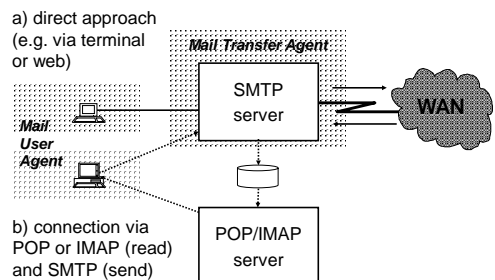

## SMTP protocol example

```
← 220 alfik.ms.mff.cuni.cz ESMTP Sendmail ...
→ HELO betynka
← 250 alfik Hello betynka, pleased to meet you
→ MAIL FROM: <forst@cuni.cz>
← 250 2.1.0 <forst@cuni.cz>... Sender ok
→ RCPT TO: <libor@forst.cz>
← 250 2.1.5 <libor@forst.cz>... Recipient ok
→ DATA
← 354 Enter mail, end with "." on a line by itself
→ From: <forst@cuni.cz>
→ To: <libor@forst.cz>
→ ...
→ .
← 250 2.0.0 h98G9FxFt Message accepted for delivery
→ QUIT
← 221 2.0.0 alfik closing connection
```

SISAL 91

Introduction to Networking (2025/6)

## Electronic mail message

```
Received: from alfik.ms.mff.cuni.cz
 by betynka.ms.mff.cuni.cz ...
Date: Thu, 16 Nov 1995 00:54:31 +0100
To: student1@ms.mff.cuni.cz
From: Libor Forst <forst@cuni.cz>
Subject: Mail test
Cc: student2@ms.mff.cuni.cz
MIME-Version: 1.0
Content-Type: multipart/mixed; boundary="=_XXX_"

--=_XXX_
Content-Type: text/plain; charset=Windows-1250
Content-Transfer-Encoding: 8bit

Čau Petře!
...
--=_XXX_==
```

Introduction to Networking (2025/6)

SISAL 92

## Mail headers

Date: mail creation date  
From: mail author(s)  
Sender: mail sender  
Reply-To: response address  
To: mail recipient(s)  
Cc: (carbon copy) additional mail copy recipient(s)  
Bcc: (blind cc) hidden recipient(s)  
Message-ID: mail identification code  
Subject: mail subject  
Received: recording of mail transfer

SISAL 93

Introduction to Networking (2025/6)

## Files and diacritics in mail

- Originally pure 7-bit ASCII, files encoding using UUENCODE (coming from UUCP, unix-to-unix-copy)

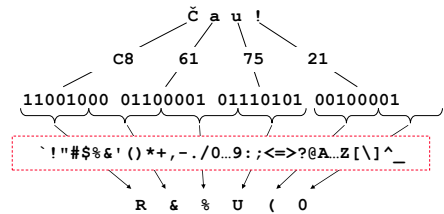

- Encoding itself is OK, but lack of methodical incorporation

Introduction to Networking (2025/6)

SISAL 94

## Multipurpose Internet Mail Extension

- RFC 2045-2049, it enables:
  - Creating structured document
  - For each part:
    - Describing content type (e.g. text/html) and format
    - Defining character set and document encoding
    - Joining additional document processing info
  - Using diacritics in (some) headers:  
Subject: =?utf-8?b?SVRBVCAyMDEyIC0gcG96?=  
• Encodings:
    - Base64: based on uuencode, table and line form changed
    - Quoted-Printable: non-ASCII chars encoded as string „=HH“, where HH is character hexadecimal value
- Nowadays widely used in other protocols, too

SISAL 95

Introduction to Networking (2025/6)

## Netiquette Guidelines

- RFC 1855
  - read all mails before answering
  - consider taking part in the discussion if you are only Cc
  - leave recipient some time to reply (checking delivery is OK)
  - answer promptly, at least as an acknowledgement
  - choose Subject carefully, check list of recipients
  - select properly language, charset, means of expression
  - leave relevant parts of the original text when answering
  - respect ©, ask original author when forwarding
  - use effective file transfer
  - check what your mailer sends (HTML but empty plaintext!)
  - don't bother people, don't overload network
  - sign

Introduction to Networking (2025/6)

SISAL 96

## Mail security (user)

- A mail is always **an open message post** (for various reasons it can be delivered to unexpected people)

*Solution:* message encryption (e.g. PGP - Pretty Good Privacy)

- The **sender** is never obvious, neither compliance of data from the envelope and the message

*Partial solution:* Sender Policy Framework, call-back attempt

*Solution:* challenge/response system, signatures

- Don't open files from unknown source!

## Mail security (client, server)

- A typical server should send mails from local clients/users to anybody, other mails only to local users; otherwise it is so called *open-relay* and there is a risk of misuse for sending mass emails and blocking of the communication by some other servers knowing about this misconfiguration.
- The same reason leads many servers used for the very first "submission" of mails (sometime called MSA) to enforce an authentication via the ESMTP command "AUTH" (it's a part of SASL profile for SMTP).
- A client can ask the server by the ESMTP command "STARTTLS" for initiating an SSL/TLS connection (e.g. between company affiliates; otherwise, the encryption is primarily the problem of end users).

## Spam protection

- Spam („spiced ham“) is an unsolicited mail, aim of which is either an advertisement, or just to annoy users
  - Grey-listing: spam-engines usually don't repeat attempts to deliver mail; the server keeps a database of triplets <client, sender, recipient>, rejects mail for the first time with the 450 response and accepts further attempts.
  - Sender Policy Framework: a domain publishes (using SPF or TXT DNS RR) algorithm how to verify that the client is authorized to send mail "from" this domain; forwarding mails causes problems.
  - DomainKeys Identified Mail (DKIM): a domain mailserver signs the text and some headers of every mail
  - Antispam: server guesses (using a configurable heuristics) the probability that a mail is a spam; disputable effectiveness and risk of *false positive* answer

## Post Office Protocol

- Protocol for remote access to user mailboxes
- Current version 3, RFC 1939, port 110
- Main disadvantages:
  - Sending passwords in plaintext; there is an extension optional command for encrypted authentication (APOP), but many clients have it unimplemented
  - message must be withdrawn in its entirety; there is also an extension optional command (TOP) for withdrawal of the message beginning, again rarely implemented
  - No support for attachment structure handling
- Nowadays supported mainly for backward compatibility and gradually replaced by IMAP
- Plaintext communication was declared Obsolete in RFC 8314

## Internet Message Access Protocol

- More powerful and more complicated successor to POP
- Current version 4rev1, RFC 9501, port 143
- Main advantages:
  - Embedded support for cryptography
  - Server keeps information about mails (status)
  - More mailboxes (folders) support
  - Commands for withdrawal of part of a mail
  - Server-side searching in mailboxes
  - Protocol contains parallel commands
- Encryption:
  - a) connection to port 993
  - b) requested by STARTTLS command
- IMAP is implemented in most current MUA

## IMAP4 example

```
← "*" OK [IMAP4REV1 STARTTLS AUTH=LOGIN] IMAP4 ready
⇒ 1 LOGIN first pwd
← 1 OK User authenticated
⇒ 2 LIST "" "*"
← * LIST (HasNoChildren) "/" "INBOX"
← 2 OK LIST completed
⇒ 2 SELECT INBOX
← * 123 EXISTS
← 2 OK [READ-WRITE] SELECT complete
⇒ 3 UID SEARCH NEW FROM "Joe" NOT BODY "Test"
← * SEARCH 1234 1248
← 3 SEARCH complete
⇒ 4 FETCH 1248 (BODY.PEEK[HEADER])
← Received: from ...
← ...
←)
```

## Voice over IP

- General name for many technologies for voice transfer over IP network
- Various methods:
  - H.323 standard
  - SIP standard
  - proprietary (Skype)
- Many problems to solve:
  - voice digitalization
  - devices capability negotiation
  - finding the target device
  - binding to regular telephony network

## H.323

- Complex solution of multimedial communication (ITU)
- Based on ASN.1 (binary, even bit-oriented protocols)
- Includes a lot of special protocols, e.g.:
  - H.225/RAS (Registration/Admission/Status) for partner searching by so called *gatekeeper* nodes
  - Q.931 (network layer ISDN) for circuit connecting
  - H.245 for dialog control (negotiation about used properties of available devices)
  - RTP channels (Realtime Transport Protocol, RFC 3550) are used for the multimedia data transfer
  - RTCP (RTP Control Protocol) controls the RTP transfer
- Today gradually replaced by SIP

## Abstract Syntax Notation 1

- Formal definition of data structures, e.g.:

```

Answer ::= CHOICE {
 word PrintableString,
 flag BOOLEAN }
AlgorithmIdentifiers ::= SET OF AlgorithmIdentifier
SignedData ::= SEQUENCE {
 version CMSVersion,
 digestAlgorithms AlgorithmIdentifiers,

```

- Comes from the 80's (and implementation looks like this)
  - e.g.: enumeration value is by default stored into as many **bits** as needed, preceded by a bit signaling an extension, meaning a **different** number of bits used for this value
- Automatic generation of protocol parser possible
- Usage examples: H.323, X.509

## Session Initiation Protocol

- Replacement of complex H.323 by simpler one
- RFC 3261, port TCP & UDP 5060
- Protocol architecture is similar to HTTP, most information carried in headers
- Does not handle the multimedia transfer itself (this is often done by RTP/RTCP channels)
- Handles only the signalization (finding the partner and contacting it)
- Data channel properties negotiation usually controlled by SDP (Session Description Protocol, RFC 8866), its data is carried encapsulated into SIP message bodies
- End node can register at some registrar and thus bind itself to regular public telephony network

## SIP session example

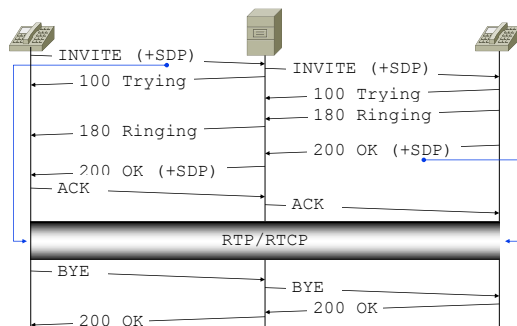

## Summary 5

- Explain MTA and MX and their role in mail transmission.
- What is an "envelope" and how does it relate to the contents of mail headers?
- How can non-ASCII characters be used in mail headers and bodies?
- How do UUENCODE, Base64 and Quoted-Printable differ?
- What is the problem with open-relay servers?
- Explain the nature of grey-listing and DKIM.

- What is the purpose of the IMAP protocol?

- Compare the H.323 and SIP protocols.

## Filesystem sharing

- Connecting a foreign filesystem transparently into local one
- Network File System (NFS)
  - originally developed at Sun Microsystems, today IETF
  - current version 4.1, RFC 8881, port 2049 (UDP, TCP)
  - source identification: server:path
  - authentication: Kerberos
  - note: relation (RPC) and presentation (XDR) layer
- Server Message Block (SMB)
  - originally developed at IBM, later adopted by Microsoft
  - open implementation Samba (UNIX)
  - source identification: UNC (\\server\_name\source\_name)
  - authentication: usually username and password

## Network Time Protocol

- Time synchronization among network nodes
  - file timestamp consistency
  - comparing logs from different machines
- Current version 4, RFC 5905, port 123 (UDP)
- Client contacts servers listed in its configuration
- Sources are classified due to accuracy and loop prevention
  - stratum 0 device: atomic clock, GPS clock
  - stratum  $N$  server: driven by stratum  $N-1$  source
- Problem: server responses have (different) delay
  - using timestamps, the most probable interval for the time response from every server is computed
  - Marzullo's algorithm is used for choosing the best intersection of intervals

## BOOTP and DHCP

- Bootstrap Protocol, RFC 951, was developed for automatic configuration of diskless stations
  - client sends (to all) a request with MAC address
  - server finds proper answer and sends IP address, name...
  - if separated by router, it must do BOOTP forwarding
- Replaced by DHCP (Dynamic Host Configuration Protocol)
  - compatible message form
  - besides the static address allocation, also dynamic one
  - limited lease time
  - more servers may co-operate
- IPv4: RFC 2131, UDP ports 67 (server) a 68 (client)
- IPv6: RFC 8415, UDP ports 546 (server) a 547 (client)
- Client chooses the best offer (by address, lease time,...)

## DHCP process

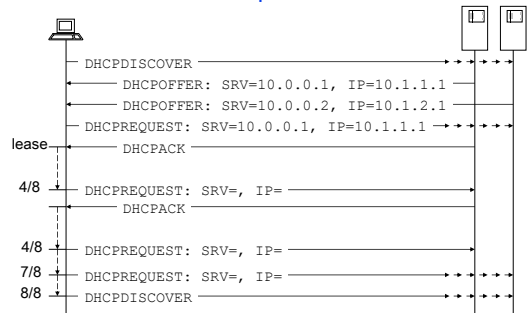

## Presentation layer (OSI 6)

- Idea of a general model describing all encoding
  - data types: integers, strings,...
  - data structures: arrays, records, pointers,...
- Very complicated in general: who and when en/decrypts
- Implementation attempt: ASN.1
- TCP/IP suppressed the need of a general model: the format definitions are included into the application protocols, conversions must be done by every application
- Practical problems:
  - textual line endings: CRLF (0x0D, 0x0A)
  - byte order: *big endian* (1 = 0x00, 0x00, 0x00, 0x01), e.g. Intel has *little endian* (1 = 0x01, 0x00, 0x00, 0x00)

## Session layer (OSI 5)

- Idea of a general dialog model
  - one dialog can consist of more connections
  - one connection can carry more dialogs
- TCP/IP suppressed the need of a general model: the dialog principle has been included directly into the application protocols, e.g.:
  - within one SMTP connection a client can send several mails to the server
  - SIP initializes dialog using more partial media data channels

## Transport layer (OSI 4)

- Layer functions:
  - is responsible for end-to-end data transfer
  - mediates network services for application protocols having various requirements to the transfer channel
  - allows running of multiple applications (both clients and servers) on the same network node
  - (optionally) guarantees data transfer reliability
  - (optionally) segments data for smoother transfer and puts them back together in proper order for applications
  - (optionally) provides data flow control (e.g. "egress speed")

## Transport layer in TCP/IP

- TCP (Transmission Control Protocol):
  - used for connection-oriented services
  - client starts a *connection*, data is sent via a *stream*
  - the connection (relation) is driven by TCP, not application
  - big overhead, TCP itself is complicated
  - less-fluent but lossless delivery
- UDP (User Datagram Protocol):
  - used for connectionless services
  - no "connection" exists in UDP, data is sent in *messages*
  - low overhead, IP and UDP are simpler
  - fluent data flow, but data loss may occur
- Some modifications/combinations, extensions: SCTP, DCCP, MPTCP, QUIC

## UDP datagram structure

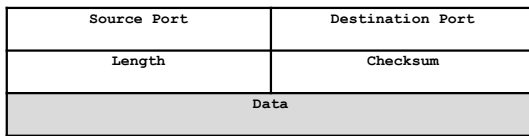

## TCP packet structure

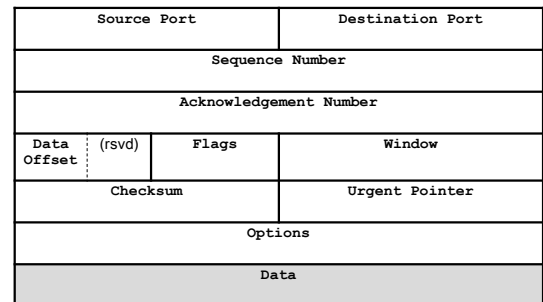

## TCP window

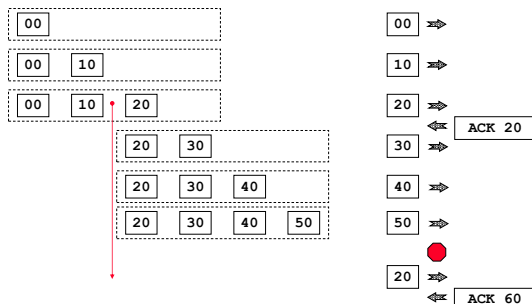

## Connection initialization and termination

- TCP connection initialization ("three-way handshake"):

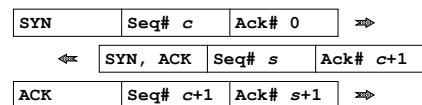

- Connection closure (one-way closure):

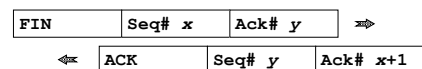

The partner (immediately, or later) closes his side, too.

## TCP flags

- **SYN** - packet for segment numbers synchronization („Sequence number“ initialization)
- **ACK** - packet acknowledges delivery of all packets up to „Acknowledgement number“ (not inclusive); packet can but need not to contain also data
- **PSH** - informs that the delivered block is completed and can be passed to the application („push“)
- **FIN** - sender closes own side of the connection, no more data will be sent
- **RST** - sender refuses to accept the connection, or immediately terminates the connection („reset“)
- **URG** - packet contains urgent (*out-of-band*) data, the address is in „Urgent pointer“

## Sample of tcpdump output

```

10.1.1.1.5471 > 1.2.3.4.25: Flags [SYN],
 seq 1620916916, win 8192 ←
real SEQ 1.2.3.4.25 > 10.1.1.1.5471: Flags [SYN,ACK],
 seq 2525839733, ack 1620916917, win 65535
relative SEQ 10.1.1.1.5471 > 1.2.3.4.25: Flags [ACK],
 ack 1, win 64240 ← window change
← 220 alfik.ms.mff.cuni.cz ESMTP Sendmail 8.15.2
1.2.3.4.25 > 10.1.1.1.5471: Flags [PSH,ACK],
 seq 1, ack 1, win 65535, length 48
10.1.1.1.5471 > 1.2.3.4.25: Flags [ACK],
 ack 49, win 64192, length 0
⇒ HELO betynka
10.1.1.1.5471 > 1.2.3.4.25: Flags [PSH,ACK],
 seq 1, ack 49, win 64192, length 14
← 250 alfik Hello betynka, pleased to meet you
1.2.3.4.25 > 10.1.1.1.5471: Flags [PSH,ACK],
 seq 49, ack 15, win 65535, length 46

```

## Existing sockets listing

```

C:\Users\forst> netstat -an
Active Connections
Proto Local Address Foreign Address State
TCP 0.0.0.0:135 0.0.0.0:0 LISTENING
TCP 0.0.0.0:623 0.0.0.0:0 LISTENING
TCP 127.0.0.1:49209 127.0.0.1:49210 ESTABLISHED
TCP 127.0.0.1:49210 127.0.0.1:49209 ESTABLISHED
TCP 192.168.28.73:139 0.0.0.0:0 LISTENING
TCP 192.168.28.73:49167 195.113.19.78:22 ESTABLISHED
TCP 192.168.28.73:49183 195.113.19.78:80 ESTABLISHED
UDP 0.0.0.0:3702 *: * *
UDP 127.0.0.1:1900 *: * *
UDP 192.168.28.73:1900 *: * *

```

TCP connection: local address / port remote address / port listening server

## Network layer (OSI 3)

- Main function: the transport of data passed down by the transport layer to the target host
- Essential operations:
  - addressing* - network layer protocols define the format and structure of communicating partners' addresses
  - encapsulation* - control data needed for the transfer (namely addresses) must be included into PDU
  - routing* - searching the best way to the target through intermediate networks
  - forwarding* - passing the data from the input network interface to the output one
  - decapsulation* - unpacking the data and passing to the transport layer
- Protocol examples: **IPv4, IPv6, IPX, AppleTalk**

## Internet Protocol (IP)

- Properties:
  - connectionless (datagrams are delivered independently)
  - best effort (unreliable, logic delegated to higher layers)
  - media independent (higher layers need not to bother with it)
- Addresses:
  - contain network address part and node address part
  - IPv4: 4 bytes, IPv6: 16 bytes
- Assignment:
  - central: IANA (Internet Assigned Numbers Authority), department of ICANN
  - regions: RIR (5x, Europe: RIPE NCC)
  - further: ISP
  - local network: network management (manually/automatically)

## IPv4 datagram structure

|                         |               |                              |                 |  |
|-------------------------|---------------|------------------------------|-----------------|--|
| Vers.                   | Header Length | Service Type (priority, QoS) | Packet Length   |  |
| Fragment Identification |               | Flags                        | Fragment Offset |  |
| Time-to-live            | Protocol      | Header Checksum              |                 |  |
| Source IP Address       |               |                              |                 |  |
| Destination IP Address  |               |                              |                 |  |
| Options                 |               |                              | Padding         |  |
| Data                    |               |                              |                 |  |

## IPv4 addresses

- Originally: one byte
- 1975 (RFC 687): three bytes („*This expansion is adequate for any foreseeable ARPANET growth.*“)
- 1976 (RFC 717): one byte (network) + three bytes (host)
- 1981 (RFC 791): classes A, B and C

| Class | byte 1 | byte 2 | byte 3 | byte 4 | 1 <sup>st</sup> byte | Nets         | Hosts |
|-------|--------|--------|--------|--------|----------------------|--------------|-------|
| A     | 0      | net    | host   |        | 1-126                | 126          | ~16 M |
| B     | 10     | net    | host   |        | 128-191              | ~16 k        | ~64 k |
| C     | 110    | net    | host   |        | 192-223              | ~2 M         | 254   |
| D     | 1110   | net    |        |        | 224-239              | multicast    |       |
| E     | 1111   |        |        |        | 240-255              | experimental |       |

## Special IPv4 addresses (RFC 5735)

- Special addresses „by design“
  - **this host** (used only as source one): 0.0.0.0/8
    - an interface with so far unassigned address
  - **loopback** (RFC 1122): 127.0.0.1/8
    - the address of local host, enables loop creation
  - **network address**: <network address>.<all 0s>
  - **network broadcast** (RFC 919): <network address>.<all 1s>
    - „to all within the net“, normally delivered to the target network
  - **limited broadcast** (RFC 919): 255.255.255.255
    - „to all within this net“, not allowed to leave the network
- Special addresses „by definition“ (not allowed to leave the network)
  - **private addresses** (RFC 1918):
    - 10.0.0.0/8, 172.16-31.0.0/16, 192.168.\*.0/24
    - for the local network traffic only, assigned by a network administrator
  - **link-local addresses** (RFC 3927): 169.254.1-254.0/16
    - for connections within local segment only, a host chooses it by itself

## Subnetting

- Network splitting by expanding network part of address:

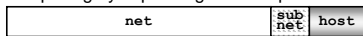

using so called network mask (*netmask*),  
in this case 255.255.255.224:

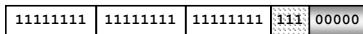

- Subnets "all-zeros" and "all-ones" are not recommended, so we have here just 6 x 30 addresses (70%)
- Non contiguous mask is possible, but usually not used
- Nowadays, the classes are often ignored (*classless mode*), using only the prefix length in bytes (e.g. 193.84.56.71/27)
- The term *variable length subnet mask* (VLSM) describes situation when various masks are used in a network
- Moving the border in opposite direction: *supernetting*

## Internet crisis

- Routing tables growth
  - Nature of the problem: large number of non contiguously assigned blocks overfills routing tables
  - Partial solutions: address reallocation, CIDR (Classless InterDomain Routing) aggregation
- Address space exhaustion
  - Nature of the problem: due to rough space fragmentation large wasting occurs
  - Partial solution: classless address blocks assigning, recycling of unused blocks, private addresses + NAT
  - End of IPv4: APNIC 2011/04, RIPE NCC 2012/09, LACNIC 2014/06, ARIN 2015/09, AFRINIC 2017/04

## IP version 6

- Long development, adopted additional instruments from IPv4
- Final address format: 128 bits (16 bytes)
- Notation: `fec0::1:800:5a12:3456/64`
- Address types:
  - **unicast** - address of one node; special ones (RFC 8200):
    - *Loopback* (::1/128)
    - *Link-Scope* (fe80::/10), formerly *link-local*
    - *Unique-Local* (fc00::/7), formerly *site-local*, analogy of private addresses in IPv4
  - **multicast** (ff00::/8) - address of group of nodes (interfaces)
  - **anycast** - formally unicast address, assigned to more nodes; routing solves delivery; intention: server distribution worldwide
  - no analogy of **broadcast**
- Migration is facilitated by various tunneling between IPv4 and IPv6

## Summary 6

- Why and how is time synchronized on hosts on the network?
- What is DHCP for?
- How does TCP/IP deal with the missing presentation layer?
- Explain the difference between TCP and UDP.
- What is TCP window for?
- What is a three-way handshake?
- How are the IPv4 classes, subnetting, and CIDR related?
- Why are there only 254 host addresses in a class C network?
- What types of broadcast addresses do we know about?

## Routing (road)

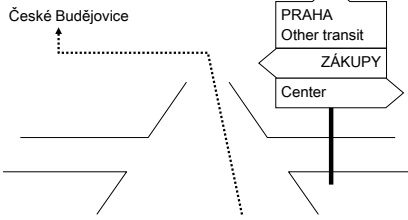

- On every crossing we decide according to signs
- For proper interpretation we need linguistic and geographic knowledge

## Routing (network)

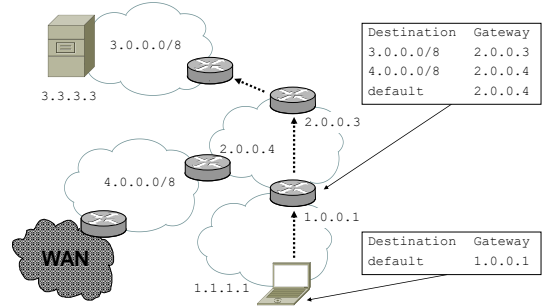

## Routing table example

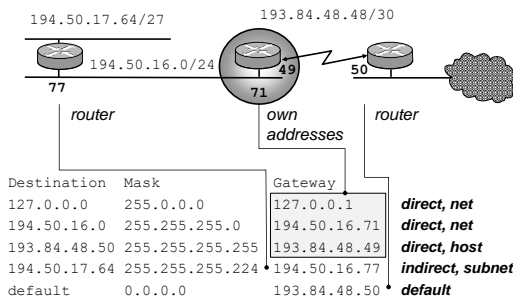

## Routing principles

- Every node in the TCP/IP network should use routing
- Routing table record contains following columns: *destination, mask, gateway*
- Mask tells „considered part“ of the destination address
- Former destination categories: host (/32), net, default (/0)
- Record types:
  - *direct* (directly connected net, “gateway” is “my” address)
  - *indirect, default*
- Record origin:
  - *implicit* (added by default after configuring an interface)
  - *explicit* (added “manually” by entering the command)
  - *dynamic* (added during the work using information sent by partners on the network)

## Routing algorithm

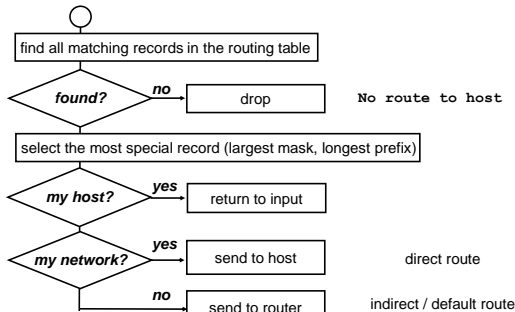

## Network configuration

### UNIX

- IP address: `ifconfig interface IP_adr [netmask mask]`
- default router: `route add default router`
- DHCP: `dhclient interface`
- usually stored in a configuration file, details vary according to the OS

### Windows

- Control Panel ⇨ Network and Internet ⇨ Network Connections ⇨ Local Area Connection ⇨ Properties ⇨ TCP/IPv4 ⇨ Properties ⇨ General
- command line commands: `ipconfig` and `route`

## Internet Control Message Protocol

- Used for sending control messages concerning IP, e.g.:
  - Echo, Echo Reply** ... host reachability test (program ping)
  - Destination Unreachable** ... host, service, or network unreachable, fragmentation needed
  - Time Exceeded** ... null TTL (routing error)
  - Source Quench** ... request to slow data flow
  - Router Solicitation, Router Advertisement** ... router discovery
  - Redirect** ... routing table change appeal
  - Parameter Problem** ... datagram header error
- Uses IP datagrams; however, no transport protocol
- ICMPv6 significantly extended and completed (e.g. by messages of pseudoprotocol Neighbor Discovery Protocol)

## Ping

- Basic tool for network diagnostics

betyнка:~> ping alfik

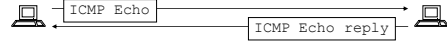

```
PING alfik.ms.mff.cuni.cz (195.113.19.71): 56 data bytes
64 bytes from 195.113.19.71: icmp_seq=0 ttl=64 time=0.214 ms
64 bytes from 195.113.19.71: icmp_seq=1 ttl=64 time=0.323 ms
64 bytes from 195.113.19.71: icmp_seq=2 ttl=64 time=0.334 ms
^C
```

```
--- alfik.ms.mff.cuni.cz ping statistics ---
3 packets transmitted, 3 packets received, 0.0% packet loss
round-trip min/avg/max/stddev = 0.214/0.290/0.334/0.054 ms
```

- no need of any special SW on the target machine
- pure network layer reachability, tells nothing about services

## Time To Live (IP)

- Mechanism defending against infinite loop in case of routing loop (e.g. erroneous router configuration)
- Number of hops the packet can still traverse
- When reaching zero, the ICMP Time Exceeded is sent

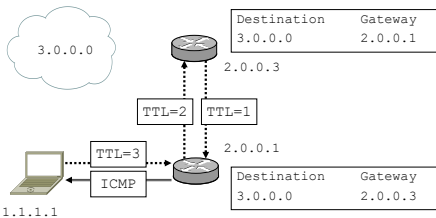

## Routing diagnostics

- Routing table listing: `netstat -r[n]` or: `route print`

| Destination | Gateway  | Flags | Ipkts | ... | Colls | Interface |
|-------------|----------|-------|-------|-----|-------|-----------|
| 194.50.16.0 | this     | U     | 15943 | ... | 0     | tu0       |
| 127.0.0.1   | loopback | UH    | ...   | ... | ...   | lo0       |
| default     | gw       | UG    | ...   | ... | ...   | tu0       |
| 193.84.57.0 | gate     | UGD   | ...   | ... | ...   | tu0       |

- Path check: `traceroute`, `tracert`

```
1 gw.thisdomain (194.50.16.222) 2 ms 1 ms 1 ms
2 gw.otherdomain (193.84.48.49) 12 ms 15 ms 15 ms
3 * * *
```

## Static management of routing tables

- Routes installed during startup by configuration
- rigid, not flexible
  - problems with subnetting
  - complicated solution of backup routes
  - + less sensitive, more robust
  - + working in totally heterogeneous environment
  - ⇒ suitable for smaller, stable networks

```
route {
 add
 delete
 flush | -f
} { [[-]host] host
 [[-]net] net [[-]netmask] mask]
 default | 0
} [gw] { router
 interface [-interface] } [metric]
```

## Redirection

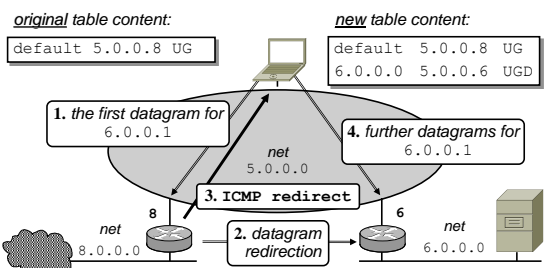

## Dynamic management of routing tables

Routers exchange information about the network using some *routing protocol*; end nodes can listen to it, too, but in read-only mode

- + simpler configuration changes
  - + network can react to failures
  - + no manual administration of routing tables needed
  - more sensitive to errors and attacks
- host must run an application handling the protocol
    - e.g. routed, gated, BIRD (developed at MFF)
    - RIP and OSPF are two of the most popular protocols for local networks (*internal routers*)

## Distance vector protocols

- Basic idea:
  - routing table records contain also "distance" (*metrics*)
  - each router sends periodically its table to all neighbors, they modify own tables and send them further
- Advantages:
  - simple, easy to implement
- Disadvantages:
  - slow reaction to failures
  - metrics poorly reflects lines properties (bandwidth, reliability, price...)
  - limited network diameter
  - one router calculation mistake affects the whole network (routing loops possible)

## Routing Information Protocol

- The oldest routing protocol, RFC 1058
- Properties:
  - metrics: path length (number of routers, *hop count*)
  - network diameter: limited to 15 hops, 16 is „infinity“
  - algorithm for getting the shortest paths: Bellman-Ford
- Current version 2, RFC 2453
  - uses UDP port 520, multicast address 224.0.0.9
  - support for subnetting incl. VLSM
  - network convergence speedup mechanisms (triggered updates, split horizon, poison reverse)
- Available on almost all systems
- Not suitable for large, complex, or rapidly changing nets

## Metrics and lines properties

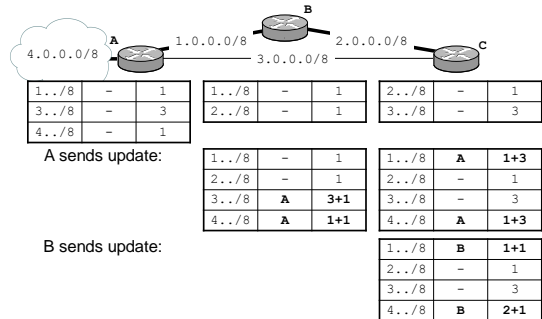

## Counting to infinity

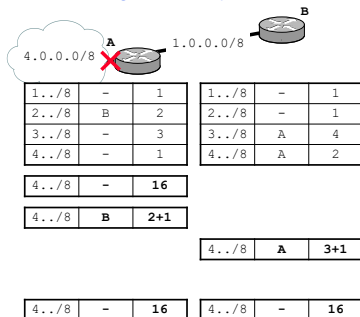

## Link state protocols

- Basic idea:
  - every router knows the entire network „map“
  - routers send neighbors state of all their links, every router uses this data for rebuilding the network map
- Disadvantages:
  - building map is CPU and memory consuming
  - during the start and in too unstable networks, the data exchanges can bring heavy network load
- Advantages:
  - flexible reaction to network topology changes
  - every router builds own map, error does not affect others
  - network can be divided to smaller areas (build speed!)
  - data exchange only in case of a failure

## Open Shortest Path First

- The most widespread link-state internal routing protocol
- Properties:
  - uses Dijkstra algorithm for the shortest path searching
  - uses a hierarchical network model:
    - area 0 is the backbone
    - other areas are connected only to the backbone
    - each router knows own area map and the path to the backbone
  - configurable metrics, by default it is *path cost*, the sum of „prices“ along the path (the price depends on the bandwidth)
- Uses own transport layer protocol (number 89) and multicast addresses 224.0.0.5 and 224.0.0.6
- Current version 2 for IPv4 (RFC 2328) and IPv6 revision marked as version 3 (RFC 5340)

## Autonomous systems

- Definition: network block with common routing policy
- Established in 1982: easier routing at the global level, using of *External Routing Protocols* (EGP)
- The most common EGP: Border Gateway Protocol (BGP)
- AS Identification: 16bit number, since 2009 moving to 32bit
- In the Czech republic: starts with 2, hundreds today

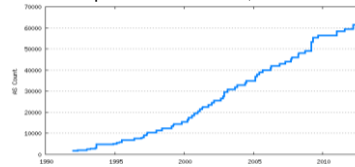

## IP filtering

- Router on the intranet/internet perimeter is configured which traffic is allowed to ingress and egress
- Strict configuration: selected out, nothing in
  - good for single-channel protocols (HTTP, SMTP)
  - poor for multiple-channel ones (FTP, SIP)
- Usual configuration: all out, nothing in
  - conflicts with e.g. FTP with active data transfer
  - unusable for protocols with many channels (SIP)
- Better solution: configuring a router, which partially understands the application layer
- Problem with services „inside“ (e.g. www server, e-mail)
  - allowing exceptions is risky
  - separated network segment, demilitarized zone (DMZ)

## Proxy server

- Transparent model:
  - SW on a **router** captures a connection, stores the request, makes its own connection to the target and sends the request.
  - The response is delivered to the router, stored (for further clients) and forwarded to the original requestor.
  - No configuration changes on client needed.
- Nontransparent model:
  - Clients need to be **configured**, to send requests to the local proxy instead of the target server (can be done automatically).
  - Proxy server need not to run on the router.
  - Only for protocols having the support for proxy usage.
- Important security and performance issue:
  - network administrator can effectively control user activities
  - outside traffic can be reasonably reduced

## Summary 7

- How does the routing algorithm work?
- Describe the types of columns and records in a routing table.
- What makes static and dynamic routing table managements different?
- What are routing protocols for?
- Compare distance-vector and link-state protocols.
- What is an autonomous system?
- Explain the meaning of the ICMP Echo, Time Exceeded and Destination Unreachable messages.
- What is the TTL field in the IP header for?
- What does IP filtering mean?
- What's a proxy server for?

## Address Resolution Protocol

- MAC (Ethernet) addresses to network (IP) ones conversion
- Unknown addresses learned using ARP broadcast requests:

|                   |           |           |
|-------------------|-----------|-----------|
| Ethernet=1        | IP=0x0800 | ARPreq=1  |
| Sender MAC        |           | Sender IP |
| FF:FF:FF:FF:FF:FF |           | Target IP |

- Results stored into node's *ARP cache*
- Unicast response (the responder must also add proper requestor data into own ARP cache)
- No proof of the authenticity of the answer (RFC 826!)
- Gratuitous ARP: unsolicited ARP (faster changes, risk)
- ARP cache listing: `arp -a`
- Limited to a link segment, OSI 3 operates between networks

## Proxy ARP

1. **host A** broadcasts **ARP request** with **host B** IP address
2. **router** knows that ARP won't succeed, thus it sends **ARP reply** with MAC address of the **router**
3. **router** MAC is assigned to the **host B** IP in ARP cache
4. **host A** sends data to **B** with the **router** MAC address

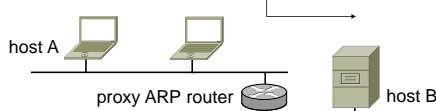

## Data link layer (OSI 2)

- Separated into two sublayers:
  - Logical Link Control (LLC) multiplexes various network layer protocols approaching a media
  - Media Access Control (MAC) controls addressing and media access: who, when and how may send and receive data
- TCP/IP does not deal with this layer („network interface“)
- Network segment (physical network):
  - set of nodes sharing the same media
- Data link layer PDU: frame
  - format depends on the media used
  - in general: synchronization field, header (addresses, type, control data), data field and trailer (Frame Check Sequence - error detection)

## Network topology

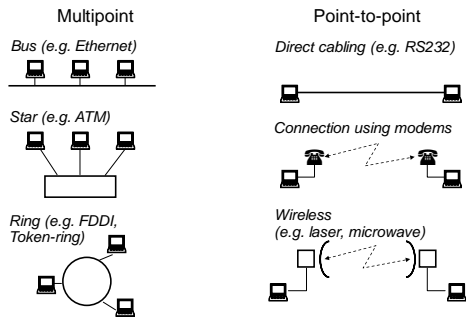

## Media access control types

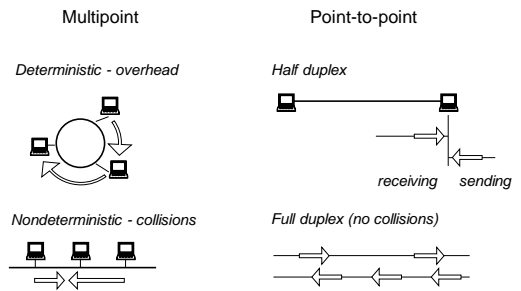

## Collision solution

- CSMA (Carrier Sense with Multiple Access)
  - a node listens carrier traffic, if not idle, waits
- CSMA/CD (Collision Detection), e.g. Ethernet
  - during the transmission checks a collision occurrence
  - if it occurs, the node stops the transmission, alerts other nodes, waits some (random) time and repeats the attempt, usually the period is increasing (*exponential waiting*)
  - constraint: frame transmission time > time to traverse the whole segment (*collision window*); maximum segment length and minimum frame size limited
- CSMA/CA (Collision Avoidance), e.g. WiFi
  - when the carrier is idle, the node sends the entire frame and waits for acknowledgement (ACK)
  - if the carrier is not idle, or the ACK does not come, the *exponential waiting* is started

## Ethernet

- History:
  - the first LAN attempts in Xerox company
  - standardization taken over by IEEE (Feb 1980 → IEEE 802)
  - two most common formats Ethernet II, IEEE 802.3
- Currently the top technology for LANs
  - can flexibly react to progressive HW evolution
  - can adapt to a wide range of transmission media
- Media access controlled by CSMA/CD
  - a „jam signal“ is sent by sender when a collision is detected
  - exponential waiting terminates after 16 attempts by an error
- Addresses:
  - 3 bytes prefix (producer, multicast...), 3 bytes node number
  - formerly „burned-in“ in NIC, nowadays programmable

## IEEE 802.3 standards

| Standard | Year | Identification | Bandwidth  | Media               |
|----------|------|----------------|------------|---------------------|
| 802.3    | 1983 | 10BASE5        | 10 Mbit/s  | thick coaxial cable |
| 802.3a   | 1985 | 10BASE2        | 10 Mbit/s  | thin coaxial cable  |
| 802.3i   | 1990 | 10BASE-T       | 10 Mbit/s  | twisted pair (UTP)  |
| 802.3j   | 1993 | 10BASE-F       | 10 Mbit/s  | fiber optic         |
| 802.3u   | 1995 | 100BASE-TX,FX  | 100 Mbit/s | UTP or fiber optic  |
| 802.3z   | 1998 | 1000BASE-X     | 1 Gbit/s   | fiber optic         |
| 802.3ab  | 1999 | 1000BASE-T     | 1 Gbit/s   | UTP                 |
| 802.3ae  | 2003 | 10GBASE-SR,... | 10 Gbit/s  | fiber optic         |
| 802.3an  | 2006 | 10GBASE-T      | 10 Gbit/s  | UTP                 |
| 802.3ba  | 2010 | 100GBASE-SR    | 100 Gbit/s | fiber optic         |

Unlike RFC, IEEE standards are licensed.

## Ethernet frame format

### Ethernet v2:

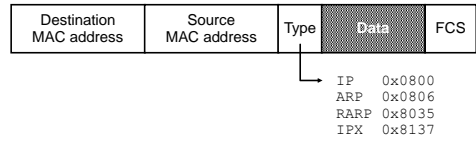

### IEEE 802.3

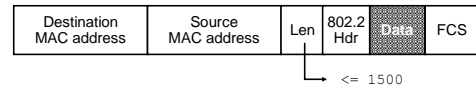

## Virtual networks (VLAN)

- VLANs allow to operate more independent local networks on a single physical infrastructure
- Networks marked by a 12bit identification (VLANID)
- Ethernet frame must be enlarged by a 32bit tag (tag protocol identifier 0x8100, QoS priority and VLANID)
- Tagging can be done by an end node or by a switch (transparently for end nodes)

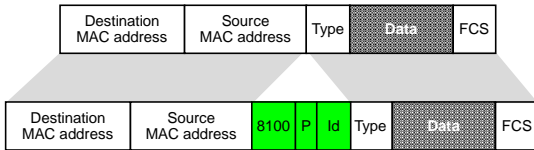

## Cyclic Redundancy Check (CRC)

- Hash function used for data integrity checks on many levels, e.g. the FCS in the Ethernet
- Bit sequence is considered as a binary polynomial coefficients

$$\boxed{\dots 1 \ 1 \ 0 \ \dots} \Leftrightarrow \dots + 1 \cdot x^{26} + 1 \cdot x^{27} + 0 \cdot x^{28} + \dots$$

- The polynomial is divided by so called *characteristic polynomial* (e.g. for CRC-16 it is  $x^{16} + x^{15} + x^2 + 1$ )
- The remainder is converted back to bits and used as a hash
- Simple implementation (also pure HW solutions)
- Big strength,  $n$ -bit CRC can detect:
  - 100% of errors with odd number of bits, or shorter than  $n$  bits
  - longer errors with high probability, too

## WiFi

- Wireless network, another name: WLAN (wireless LAN)
- Many various models commonly called IEEE 802.11 (802.11a, b, g, n, y,...):
  - various frequencies (2,4 to 5 GHz)
  - various speeds (2 to 600 Mbps)
- WiFi devices embedded to almost all communication tools
- Network structure:
  - ad-hoc peer-to-peer network
  - infrastructure of access points (AP)
- SSID (Service Set ID): string (up to 32 characters) for network distinguishing
- Problem: **security!**

## Physical layer (OSI 1)

- Layer function:
  - data transfer over physical media
  - conversion from digital data to analogue signal and v.v.
- Various media types
  - metallic: electric pulses
  - optical: light pulses
  - wireless: wave modulation

## Data transfer modes

- Analogue vs. digital
  - in fact, everything is analogue (e.g. electric current)
  - digital: thresholds exist that decide whether a signal level belongs to proper interval (less impact of noise)
  - converters: A→D (and back) *codec* (coder/decoder)  
D→A *modem* (modulator/demodulator),
- Baseband vs. broadband
  - baseband carries directly encoded signal itself, the Ethernet uses so called Manchester:

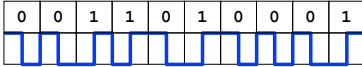

- broadband carries the basic signal and modulates it (phase, amplitude, frequency)

## Unshielded Twisted Pair (UTP)

- The most common structured cabling media nowadays
- 4 pairs of copper conductors twisted around each other
  - twisting lowers both emission and reception of electromagnetic radiation (lower interference)
- 100Mb Ethernet uses only 2 pairs (cable can be "divided")
- Connectors: RJ 45
- Cabling must reflect the nature of devices
  - nowadays usually the MDI/MDIX autodetection available



- Option: cable with metallic shielding (STP)
- Introduction to Networking (2025/6) SISAL 170

## Optical fiber

- Signal is carried as visible light through a fiber of SiO<sub>2</sub>
  - high frequency, large bandwidth
  - low attenuation, no interference
- Disadvantages:
  - higher price, demanding installation, **don't look into cable**
- Fiber types:
  - singlemode fiber - light source: laser => single wave, higher radius, bandwidth („speed“, not speed), price
  - multimode fiber - light source: LED

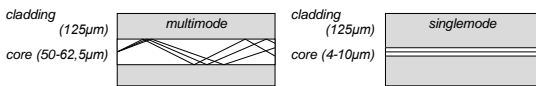

## Network segmentation

- Repeaters connect segments on the physical layer
  - solves: larger radius (eliminates cable attenuation)
  - does not solve: throughput (collision probability increases)
  - terminology of structured cabling: *hub*
- Bridges connect segments on the data link layer
  - solves: larger throughput (by splitting the collision domain)
  - terminology of structured cabling: *switch*

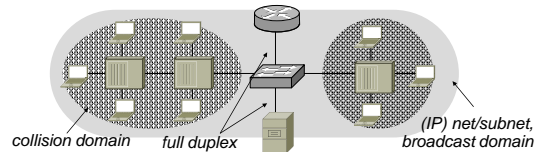

## Learning bridge, BUM (BUS)

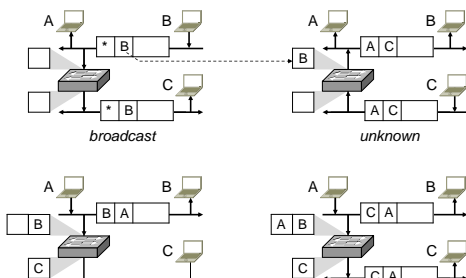

## Spanning Tree Algorithm

- If two segments are connected by two switches, the network is flooded by forwarded frames, the learning bridge doesn't work

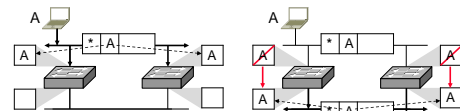

- Reason: the graph contains a loop
- Solution: to find an acyclic subset, spanning tree
- Switches must agree, which acts as backup one (forwarding no data, only monitoring status)
- Protocol (STP) needs timeouts, switch port start is slow
  - usually, the STA can be suspended („faststart“), use carefully

## Summary 8

- Describe the purpose and safety risks of ARP.
- Describe the purpose of the LLC and MAC layers.
- What is the difference between the physical and logical topology of a network?
- What is a collision, where can it occur and how is it dealt with?
- What is a VLAN for and how is it implemented?
- What is a CRC for and how does it work?
  
- Describe how data is transmitted depending on the underlying medium.
- Describe the various types of metallic and optical cables.
- What is a learning bridge and STP?

The End